

## Paper Slitter Rewinder - PSR

### Features

- ★ Branded electric components
- ★ Double rotary cutting blade
- ★ Cantilever for paper unloading
- ★ Oil-pressure swing arm for loading
- ★ Convenient paper loading system
- ★ Using cutting system with self-adaption function

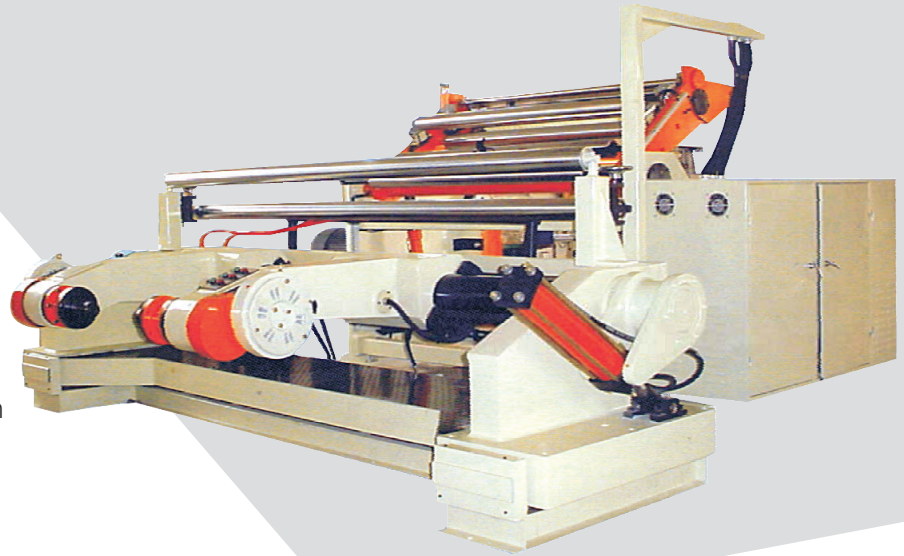

### Process Diagram

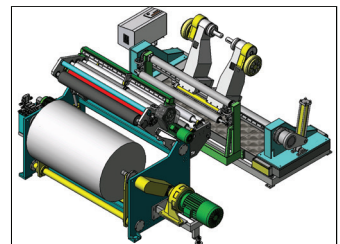
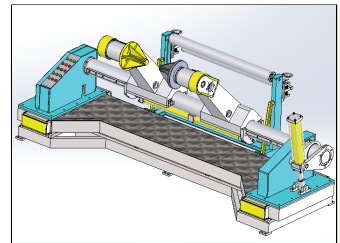
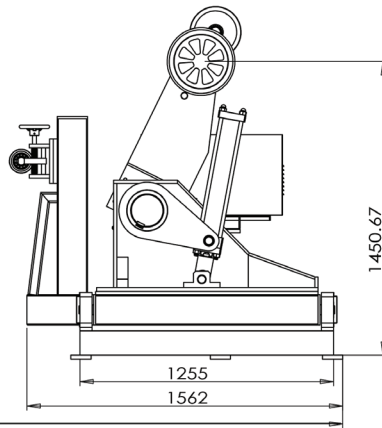
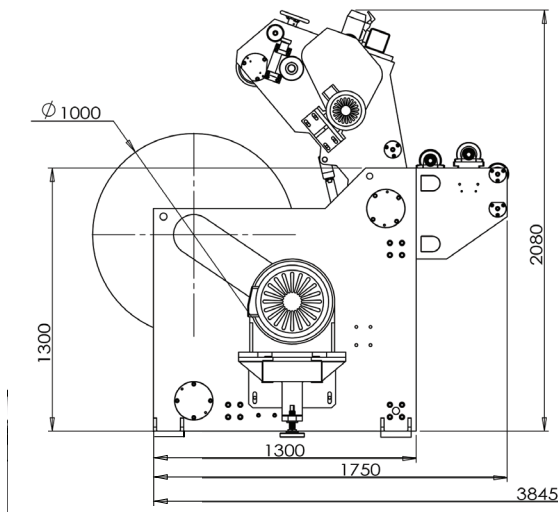

### Specifications

Model	PSR-1700	PSR-1800	PSR-1900	PSR-2500
<b>Paper Loading Platform without Core, with Full Hydraulic System</b>				
Paper Media	White Paper/Kraft Paper/Cardboard			
Paper Weight	35-120 gsm			
Max Diameter of Input Roll	MaxΦ1600mm			
Max Width of Input Roll	1700mm or 66"	1800mm or 71"	1900mm or 74"	2500mm or 98"
<b>EPC Edge Tracking System</b>				
Tension of Input Roll	2x20kg Magnetic Powder Braking System Automatic Tension Controlling Device			
Max Cutting Width	1700mm or 66"	1800mm or 71"	1900mm or 74"	2500mm or 98"
Min Cutting Width	20mm or 0.8"			
Max Cutting Speed	250m/min			
Max Diameter of Rewinding Roll	1200mm/6"			
Power of Rewinding Motor	18.5KW	18.5KW	22KW	22KW
Standard Voltage	Ac380V/50HZ			

★ All Parts are eligible for 15 months warranty under proper use. (Starting from ETD)  
 ★ Specifications and external appearance are subject to change without prior notice.